

THE INFORMATION CONTAINED IN THIS DRAWING IS THE SOLE PROPERTY OF PLASTICASE ANY REPRODUCTION IN PART OR WHOLE WITHOUT THE WRITTEN PERMISSION OF PLASTICASE IS PROHIBITED.

REVISIONS			
REV.	DESCRIPTION	DATE	APPROVED

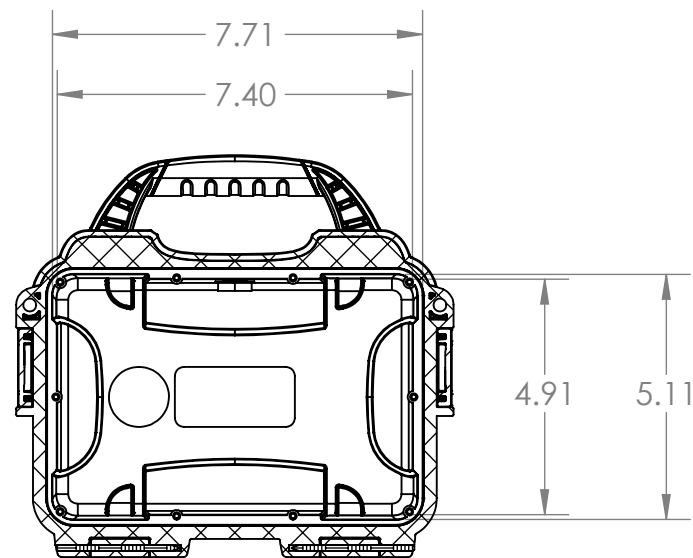

SECTION A-A

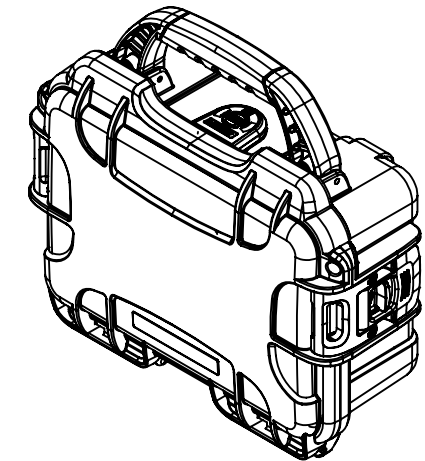
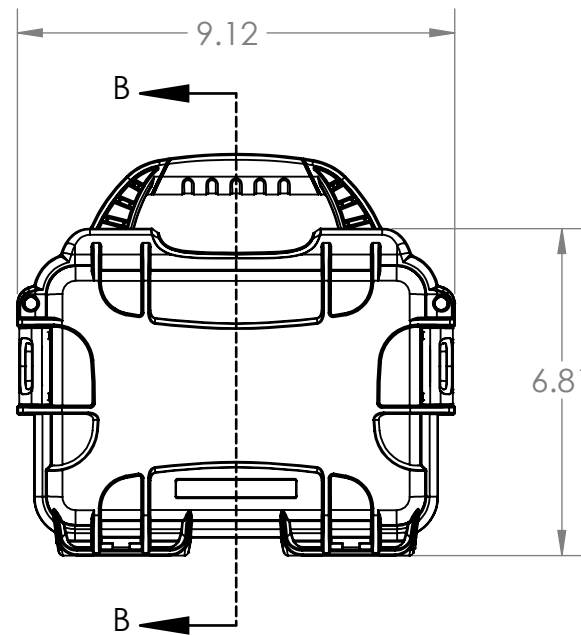
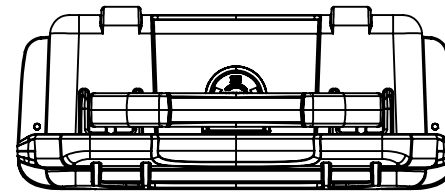
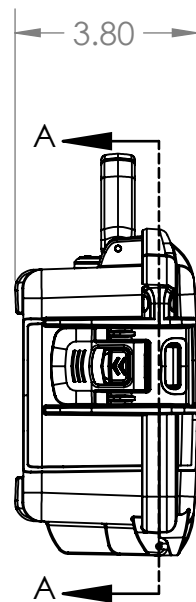
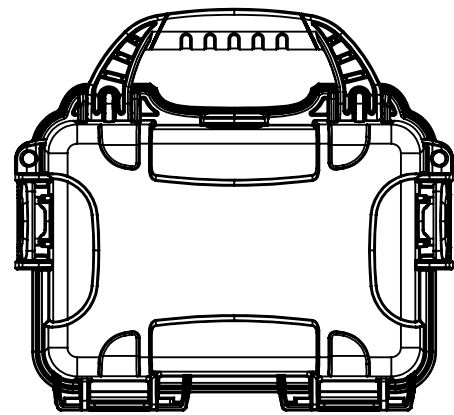
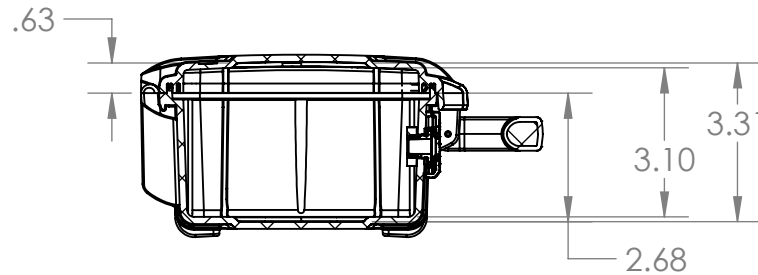

SECTION B-B

### NANUK 903 Specifications

Case Weight Empty	1.3lbs / 0.6kg
Interior Length	7.40" / 188mm
Interior Width	4.91" / 125mm
Interior Height	3.31" / 84mm
Interior Lid Depth	0.63" / 16mm
Interior Base Depth	2.68" / 68mm
Exterior Length	9.12" / 232mm
Exterior Width	6.81" / 173mm
Exterior Height	3.80" / 97mm
Master Pack Qty.	10
Master Pack Wt.	16.05lbs / 7.28kg
Max Buoyancy	N/A

### PARTS LIST

UNLESS OTHERWISE SPECIFIED DIMENSIONS ARE IN INCHES	CAD GENERATED DRAWING, DO NOT MANUALLY UPDATE		PLASTICASE
	APPROVALS	DATE	
	DRAWN P.L.O.	25/10/2013	
	CHECKED		
MATERIAL	RESP ENG		NANUK 903
FINISH --	MFG ENG		
DO NOT SCALE DRAWING	QUAL ENG		
	SIZE B	DWG. NO.	REV.
	SCALE 1:4	CAD FILE: 903_ASSEMBLY_Curve_REV\$SHEET 1 OF 1	