

THE INFORMATION CONTAINED IN THIS DRAWING IS THE SOLE PROPERTY OF PLASTICASE ANY REPRODUCTION IN PART OR WHOLE WITHOUT THE WRITTEN PERMISSION OF PLASTICASE IS PROHIBITED.

REVISIONS			
REV.	DESCRIPTION	DATE	APPROVED

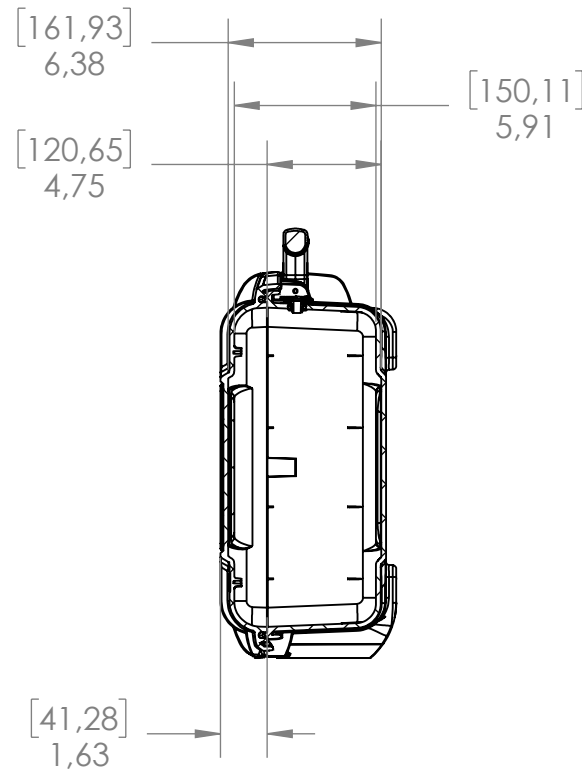
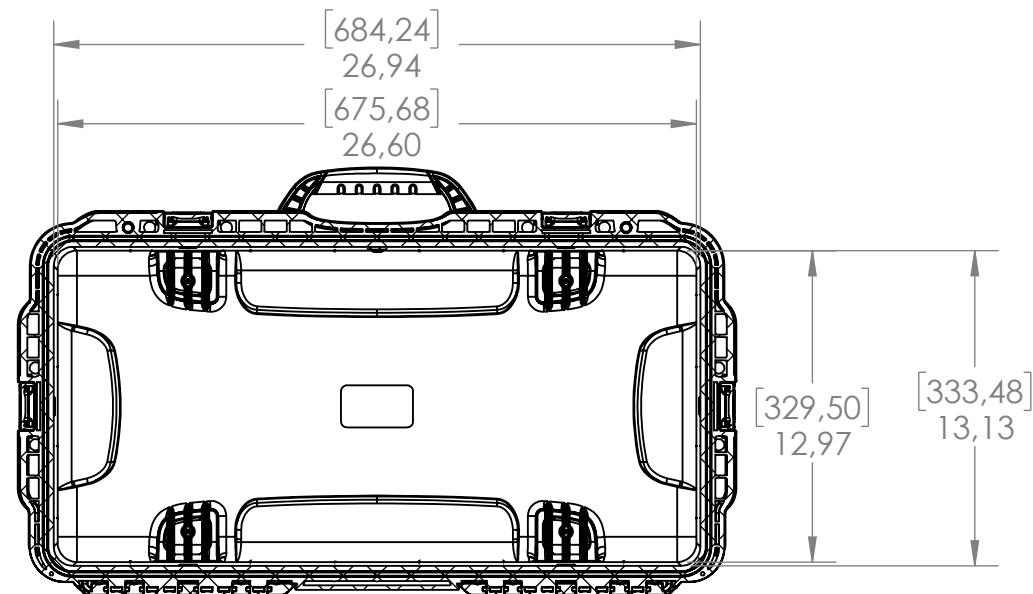
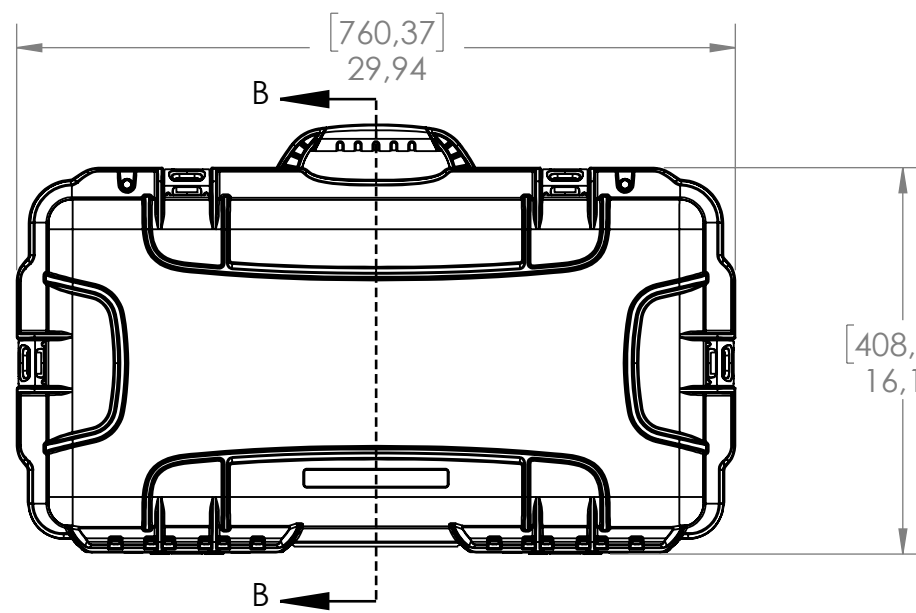
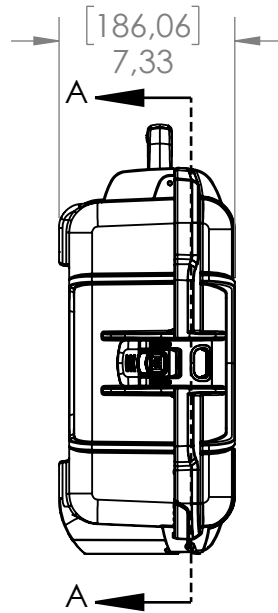
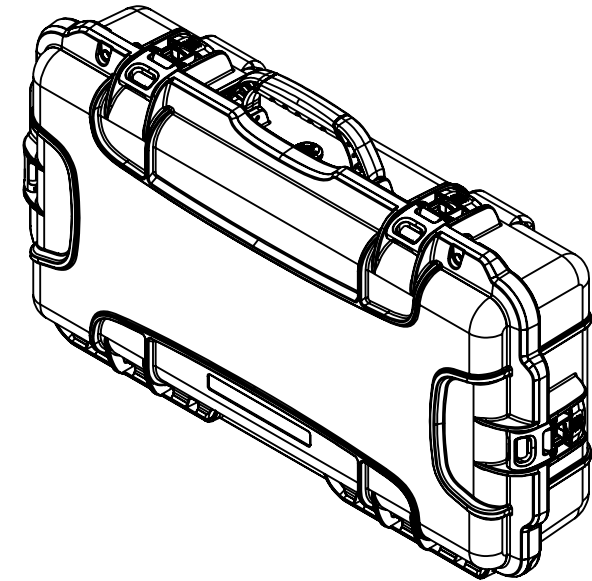
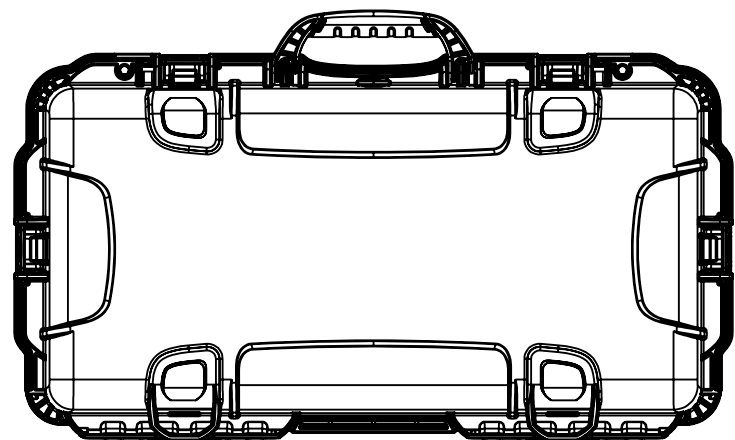
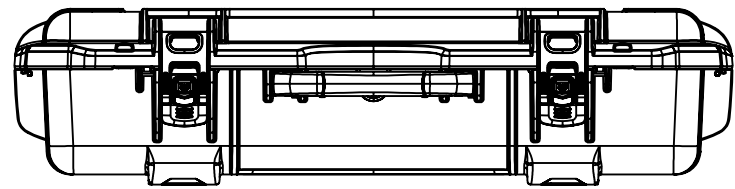

SECTION A-A
SCALE 1 : 8

SECTION B-B
SCALE 1 : 8

NANUK 980 Specifications	
Case Weight Empty	10.8lbs / 4.9kg
Interior Length	26.9" / 684mm
Interior Width	13.1" / 333mm
Interior Height	6.3" / 161mm
Interior Lid Depth	1.6" / 41mm
Interior Base Depth	5.91" / 150mm
Exterior Length	29.9" / 760mm
Exterior Width	16.1" / 408mm
Exterior Height	7.3" / 186mm
Master Pack Qty.	1
Master Pack Wt.	N/A
Max Buoyancy	N/A

PARTS LIST			
UNLESS OTHERWISE SPECIFIED DIMENSIONS ARE IN INCHES	CAD GENERATED DRAWING, DO NOT MANUALLY UPDATE		<p>PLASTICASE</p> <p>NANUK 980</p>
	APPROVALS	DATE	
	DRAWN MK	2023-01-25	
	CHECKED		
MATERIAL	RESP ENG		
FINISH --	MFG ENG		
DO NOT SCALE DRAWING	QUAL ENG		
SIZE B	DWG. NO.	REV.	
SCALE 1:12	CAD FILE: 980_Assembly_a.03	SHEET 1 OF 1	